

ASPKGU101/BK

IP65 GU10 Garden Spike



PRODUCT FEATURES

- Black Powder Coat Finish
- Cast Aluminium Body
- Wall Mountable
- IP65
- Pre-Wired With 2m Cable
- 5mm Tempered Glass
- GU10 Lamp Holder For Interchangeable Lamps
- Supplied with Spike

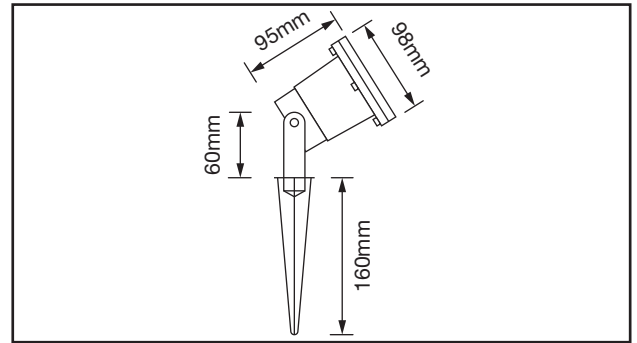

TECHNICAL SPECIFICATIONS

PRODUCT CODE	ASPKGU101/BK
Maximum Wattage	25W GU10
Operating Voltage	200-240VAC
Frequency	50-60Hz
Cable Length	2m
Ingress Protection	IP65
Paint Finish	Black (Powder Coat)

